

### Description

The P1482/P1482B series is a low voltage, single P-MOSFET high-side power switch, optimized for self-powered and bus-powered Universal Serial Bus (USB) applications. The switch's low RDS(ON), 75mΩ, meets USB voltage drop requirements; and a flag output is available to indicate fault conditions to the local USB controller.

Additional features include soft-start to limit inrush current during plug-in, thermal shutdown to prevent the switch failure from high-current loads, under-voltage lockout (UVLO) to ensure that the device remains off unless there is a valid input voltage present. The maximum current is limited to typically 2A through the switch, lower quiescent current as 25uA making this device ideal for portable battery-operated equipment.

The P1482/P1482B is available in SOT-23-5L package.

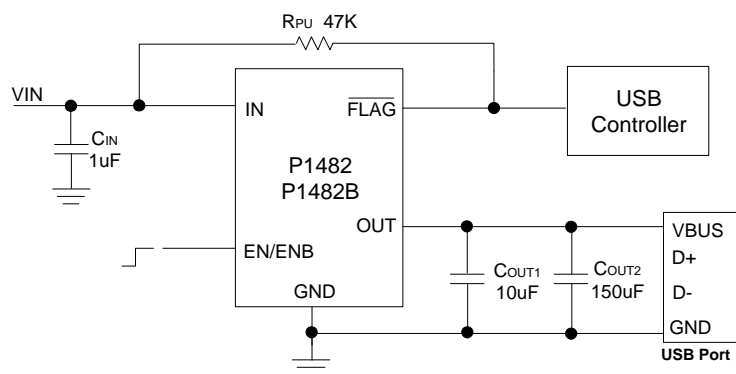

Figure 1: Typical Application

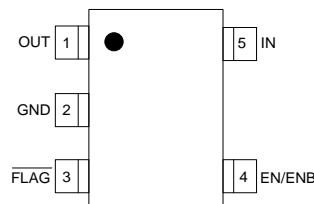

Figure 2: Pin order (Top view)

### Features

- Wide Input Voltage Ranges : 2.5V to 5.5V
- Typical RDS(ON) :75mΩ
- 1.7V Typical Under-Voltage Lockout (UVLO)
- Output Can Be Forced Higher Than Input
- Low Supply Current :
  - 25uA Typical at Switch on State
  - 1uA Typical at Switch off State
- Current Limit Protection(Typ): 2A
- Open-Drain Fault Flag Output
- Hot Plug-In Application (Soft-Start)
- Thermal Shutdown Protection
- Reverse Current Flow Blocking (no body diode)

75mΩ, 2 A Current Limited, Power Distribution Switches

Applications

- USB Bus/Self Powered Hubs
- USB Peripherals
- ACPI Power Distribution
- PC Card Hot Swap
- Notebook, Motherboard PCs

Pin Definitions

Pin No.	Symbol	Descriptions
1	OUT	Switch output Terminal.
2	GND	Ground Terminal. Connect to the thermal pad and to the ground rail of the circuit.
3	----- FLAG	Open-drain Fault FLAG Output. FLAG is pulled to GND with a 110Ω resistant internally When any of current-limit or over-temperature protection occurs, the FLAG goes low. FLAG is high impedance during normal operation.
4	EN	Enable Input. Pulling this pin to high will enable the device and pulling this pin to low will disable device. The EN pin cannot be left floating.(For P1482)
	ENB	Enable Input. Pulling this pin to high will disable the device and pulling this pin to low will enable device. The ENB pin cannot be left floating.(For P1482B)
5	IN	Switch Input and Device Power Supply.

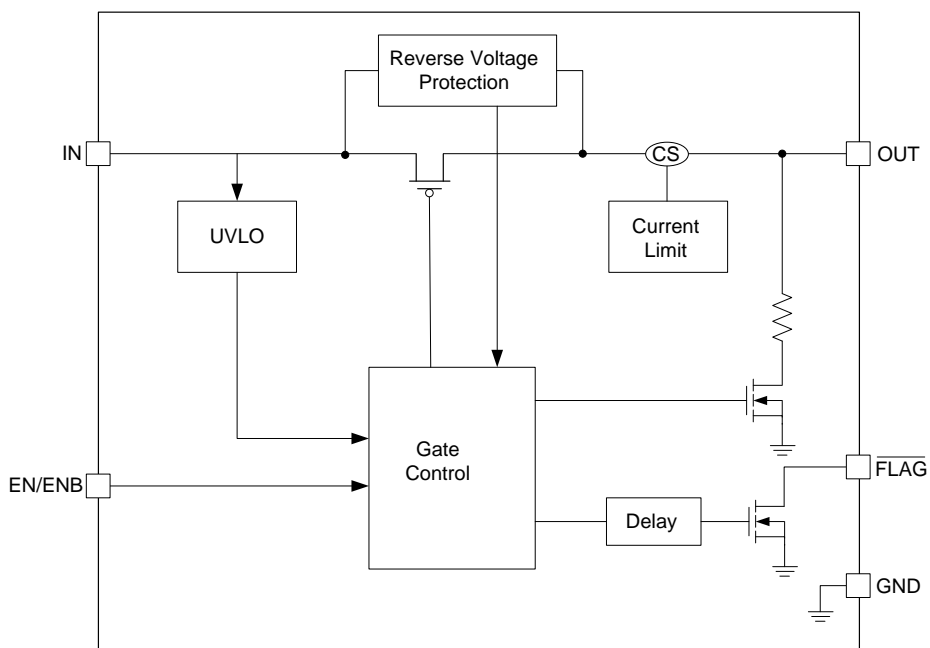

Figure 3: IC Block Diagram

**75mΩ, 2 A Current Limited, Power Distribution Switches**
**Ordering Information**

Part Number	Package	Enable Definition	Current Limit Setting
P1482	SOT23-5L	Active High	Fixed 2A
P1482B	SOT23-5L	Active Low	Fixed 2A

**Absolute maximum rating**

Parameter(Note1)	Symbol	Value	Units
Input voltage (IN pin)	$V_{IN}$	-0.3 ~ 6.0	V
Output voltage (OUT pin)	$V_{OUT}$	-0.3 ~ 6.0	V
Enable voltage (EN pin)	$V_{EN}$	-0.3 ~ 6.0	V
Flag voltage (FLAG pin)	$V_{FLAG}$	-0.3 ~ 6.0	V
Junction temperature	$T_J$	150	°C
Lead temperature(10s)	$T_L$	260	°C
Storage temperature	$T_{STG}$	-55~150	°C
ESD Ratings	HBM	±2000	V
	CDM	±500	V

**Note 1:** Stresses greater than those listed under "Absolute Maximum Ratings" may cause permanent damage to the device. These are stress ratings only, and functional operation of the device at these or any other conditions beyond those indicated under "Recommended Operating Conditions" is not implied. Exposure to "Absolute Maximum Ratings" for extended periods may affect device reliability.

**Recommended Operating Conditions**

Parameter	Symbol	Value	Units
Input voltage	$V_{IN}$	2.5~5.5	V
MAX Continuous Output current	$I_{OUT}$	0~1.6	A
Ambient operating temperature	$T_{OPR}$	-40~85	°C
Junction temperature	$T_J$	-40~125	°C

**Electrical Characteristics**

Parameter	Symbol	Conditions	Min.	Typ.	Max.	Units
Input voltage range	$V_{IN}$		2.5		5.5	V
Switch on resistance	$R_{ON}$	$V_{IN}=5V, I_{OUT}=1A$		75		mΩ
Quiescent current	$I_Q$	Switch on, NO LOAD		25	45	μA
Switch off leakage current	$I_{OFF}$	Switch off, NO LOAD		0.1	1	μA
Current Limit Threshold	$I_{LIM}$		1.8	2	2.2	A
EN high threshold voltage	$V_{EN,H}$	$V_{IN} = 2.5V$ to 5.5V	2.0			V
EN low threshold voltage	$V_{EN,L}$	$V_{IN} = 2.5V$ to 5.5V			0.6	V
EN Input current	$I_{EN}$	$V_{EN}=0V$ to 5.5V			1	μA
Output Standby current	$I_{SDY}$	$V_{IN}=0V, V_{EN}=0V, V_{OUT}=5V$		14	25	μA
Input Leakage current	$I_{IN,LEAK}$	$V_{IN}=0V, V_{EN}=0V, V_{OUT}=5V$			1	μA
Output Turn-On Rise Time	$t_{ON}$	10% to 90% of $V_{OUT}$ rising		470		μs
FLAG Output Resistance	$R_{FLAG}$	$I_{SINK}=1mA$		110		Ω
FLAG Off Current	$I_{LEAK\_FLAG}$	$V_{FLG}=5V$		0.01	1	μA
FLAG Delay Time	$t_{D\_FLAG}$	From fault condition to FLAG assertion	5	12	20	ms
Power on delay time	$t_{D\_ON}$		5	12	20	ms
Enable on delay time	$t_{D\_EN}$			100		μs
Enable off delay time	$t_{D\_DIS}$			5		μs
Response time of over current	$t_{D\_OCP}$			100		μs
Shutdown Pull-Low Resistance	$R_{DIS}$	$V_{EN}=0V$		130		Ω
Under-Voltage Lockout	$V_{UVLO}$	$V_{IN}$ increasing	1.3	1.7		V
Under-Voltage Hysteresis	$V_{UVLO\_HYS}$	$V_{IN}$ decreasing		0.1		V
Thermal Shutdown Protection				150		°C
Thermal Shutdown Hysteresis				20		°C

Typical Operating Performance



Power on Response (No Load)

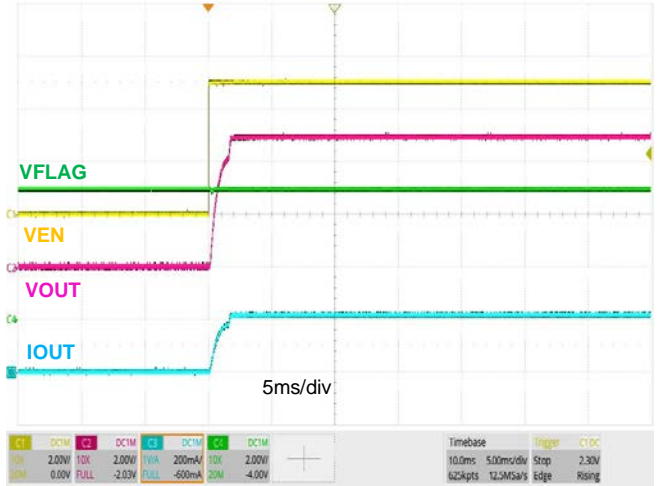

Enable Response ( $R_L=20\Omega$ )

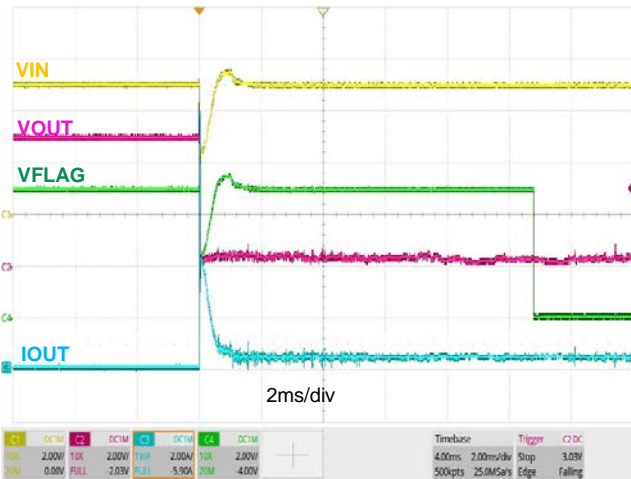

Output Short Response

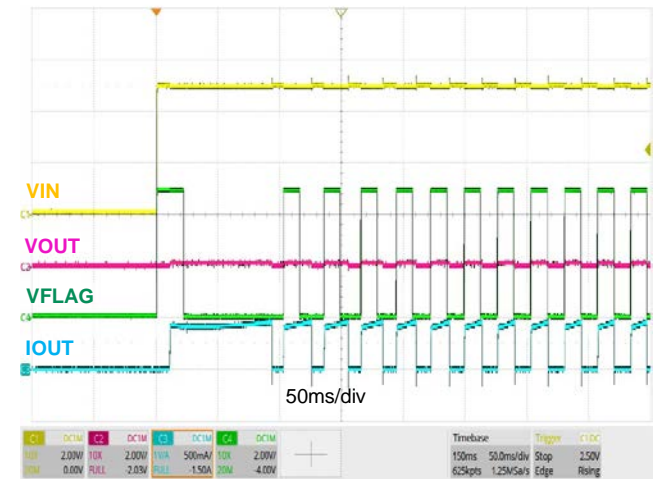

Power on Response in Output Short

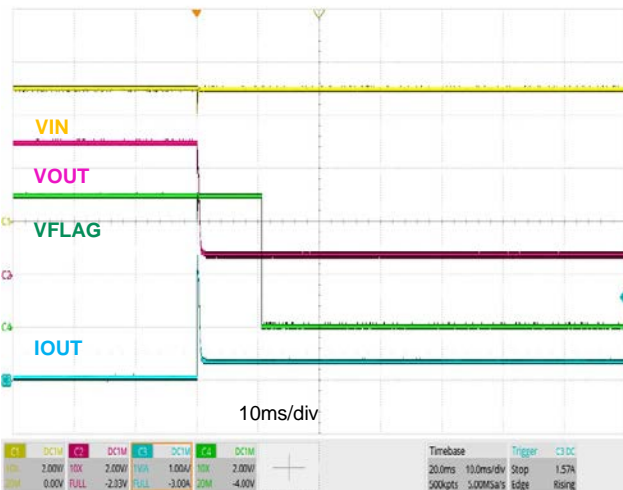

OCP Response



OTP Response

**Function Descriptions****1. Under-voltage Lockout (UVLO)**

Under-voltage lockout (UVLO) prevents the MOSFET switch from turning on until input voltage exceeds approximately 1.7V. If input voltage drops below approximately 1.6V, UVLO turns off the MOSFET, FLG will be asserted accordingly.

**2. Fault Flag**

The ICs provides a FLAG signal pin which is an N-Channel open drain MOSFET output. This open drain output goes low when current limit, the die temperature exceeds 150°C approximately occurs. The /FLAG pin requires a pull-up resistor, this resistor should be large in value to reduce energy drain. A 47kΩ pull-up resistor works well for most applications. In the case of an over-current condition, FLG will be asserted only after the flag response delay time,  $t_{D\_FLAG}$ , has elapsed. This ensures that FLG is asserted only upon valid over-current conditions.

**3. Current Limiting and Short-Circuit Protection**

The current limit circuitry prevents damage to the MOSFET switch and the hub downstream port but can deliver load current up to the current limit threshold of typically 2A through the switch. When a heavy load or short circuit is applied to an enabled switch, a large transient current may flow until the current limit circuitry responds is about 100us. Once this current limit threshold is exceeded the device enters constant current mode until the thermal shutdown occurs or the fault is removed.

**4. Thermal Shutdown**

Thermal shutdown is employed to protect the device from damage if the die temperature exceeds approximately 150°C. When the device's junction temperature cools by 20C°, the internal thermal sense circuit will enable the device, resulting in a pulsed output during continuous thermal protection.. The output and FLG signal will continue to cycle on and off until the device is disabled or the fault is removed.

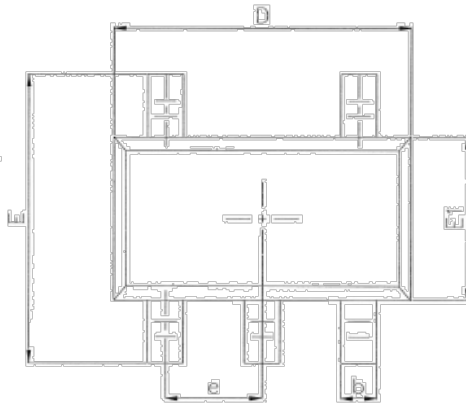
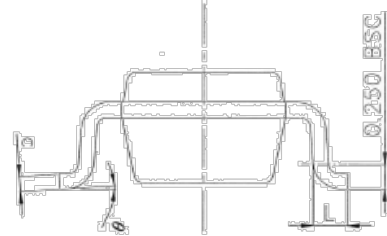
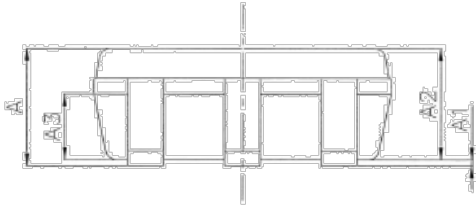
**Product dimension (SOT23-5L)**

Dim	Millimeters		
	MIN	NOM	MAX
A	1.050	1.150	1.250
A1	0.000	0.060	0.100
A2	1.000	1.100	1.200
A3	0.550	0.650	0.750
D	2.820	2.920	3.020
E1	1.510	1.610	1.700
E	2.650	2.800	2.950
b	0.300	0.400	0.500
e	0.950BSC		
θ	0°	4°	8°
L	0.300	0.420	0.570
c	0.100	0.152	0.200

**IMPORTANT NOTICE**

 and **Prisemi**<sup>®</sup> are registered trademarks of **Prisemi Electronics Co., Ltd (Prisemi)** ,Prisemi reserves the right to make changes without further notice to any products herein. Prisemi makes no warranty, representation or guarantee regarding the suitability of its products for any particular purpose, nor does Prisemi assume any liability arising out of the application or use of any product or circuit, and specifically disclaims any and all liability, including without limitation special, consequential or incidental damages. “Typical” parameters which may be provided in Prisemi data sheets and/or specifications can and do vary in different applications and actual performance may vary over time. All operating parameters, including “Typical” must be validated for each customer application by customer’s technical experts. Prisemi does not convey any license under its patent rights nor the rights of others. The products listed in this document are designed to be used with ordinary electronic equipment or devices, Should you intend to use these products with equipment or devices which require an extremely high level of reliability and the malfunction of with would directly endanger human life (such as medical instruments, aerospace machinery, nuclear-reactor controllers, fuel controllers and other safety devices), please be sure to consult with our sales representative in advance.

Prisemi reserves the right to change the circuitry and/or specifications without notice at any time. Customers should obtain the latest relevant information and datasheets before placing orders and should verify that such information is current and complete.

Website: <http://www.prisemi.com>

For additional information, please contact your local Sales Representative.

©Copyright 2009, Prisemi Electronics

 **Prisemi**<sup>®</sup> is a registered trademark of Prisemi Electronics.

All rights are reserved.