

Description

The P14C10 is an Over-Voltage-Protection (OVP) load switch with fixed 5.8V OVLO threshold voltage. The device will switch off internal MOSFET to disconnect IN to OUT to protect load when any of input voltage over the threshold. The Over temperature protection (OTP) function monitors chip temperature to protect the device. The P14C10 is available in Green SOT23 package.

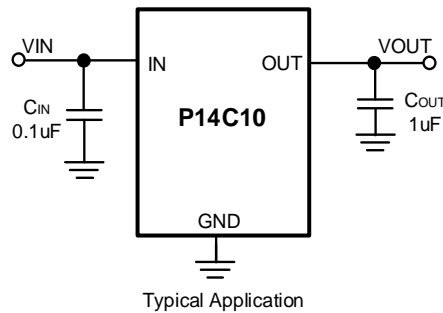

Figure 1: Application Circuit

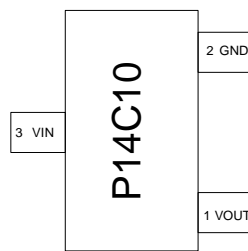

Figure 2: Pin order and Marking (Top view)

Feature

- Maximum input voltage : 30V
- Ultra fast OVP response time: 50ns (Typ.)
- Fixed OVLO threshold voltage: 5.8V, $\pm 3\%$
- Fixed OCP threshold current: 1.1A, $\pm 10\%$
- 340m Ω on resistance
- Thermal Shutdown
- Available in Green SOT23 Package

Application

- TWS
- Portable Media Players
- Low-Power Handheld Devices

Pin Definitions

Pin No.	Symbol	Descriptions
1	OUT	Switch output Terminal.
2	GND	Ground Terminal.
3	IN	Switch Input and Device Power Supply.

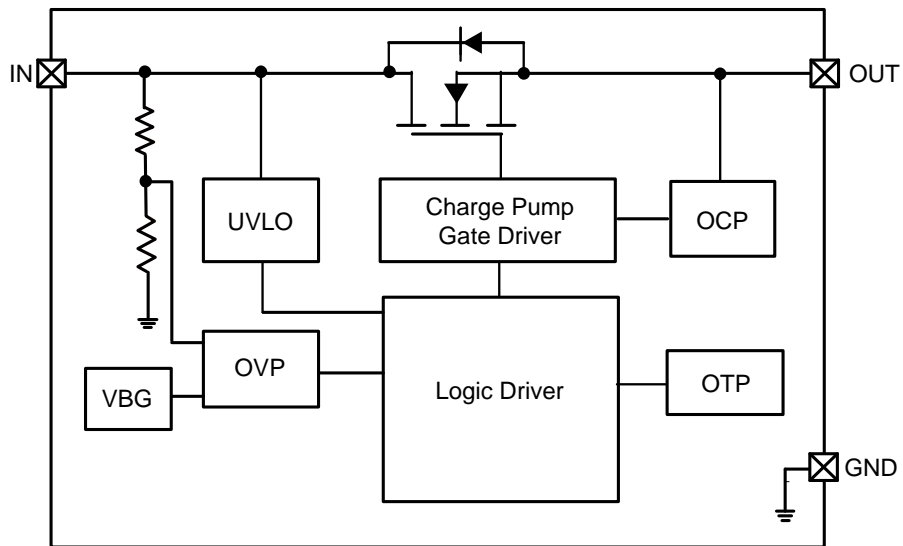

Figure 3: IC Block Diagram

Ordering Information

ORDER NUMBER	MARKING	PACKAGE	Q'TY/BY REEL
P14C10	P14C10	SOT23	3000 / Tape & Reel

Absolute maximum rating

Parameter(Note1)	Symbol	Value	Units
Input voltage (IN pin)	V_{IN}	-0.3 ~ 30	V
Output voltage (OUT pin)	V_{OUT}	-0.3 ~ 6.5	V
Junction temperature	T_J	150	°C
Lead temperature(10s)	T_L	260	°C
Storage temperature	T_{stg}	-55~150	°C
Thermal Resistance	θ_{JA}	270	°C/W
ESD Ratings	HBM	±2000	V
	CDM	±500	V

Note 1: Stresses greater than those listed under "Absolute Maximum Ratings" may cause permanent damage to the device. These are stress ratings only, and functional operation of the device at these or any other conditions beyond those indicated under "Recommended Operating Conditions" is not implied. Exposure to "Absolute Maximum Ratings" for extended periods may affect device reliability.

Recommended Operating Conditions

Parameter	Symbol	Value	Units
Input voltage	V_{IN}	3~30	V
MAX Continuous Output current	I_{OUT}	1.0	A
Ambient operating temperature	T_{opr}	-40~85	°C

Over voltage protector

Electrical Characteristics

($T_A=25^{\circ}\text{C}$, $V_{IN}=5\text{V}$, $C_{IN}=0.1\mu\text{F}$, $C_{OUT}=1\mu\text{F}$, unless otherwise specified.)

Parameter	Symbol	Conditions	Min.	Typ.	Max.	Units
General Function						
Input voltage range	V_{IN}		3		30	V
Quiescent current	I_Q	NO Load, $V_{IN}=5\text{V}$		60		μA
Over voltage quiescent current	I_{Q_OVP}	NO Load, $V_{IN}=30\text{V}$		120		μA
On resistance	R_{on}	$V_{IN}=5\text{V}$, $I_{OUT}=1.0\text{A}$		340		$\text{m}\Omega$
Turn On Time	t_{ON}	$V_{OUT}=V_{IN}*10\%$ to $V_{OUT}=V_{IN}*90\%$		400		μs
OVP Function						
OVP response time	t_{OVP}	V_{IN} rising, $C_{IN}=C_L=0\text{pF}$ (Note2)		50		ns
OVP voltage	V_{OVLO}	V_{IN} rising	5.6	5.8	6.0	V
Output discharge resistance	R_{DCHG}	$V_{IN}=5\text{V}$		1.5		$\text{k}\Omega$
OCP Function						
OCP current	I_{OCP}	Current Rising		1.1		A
OCP accuracy	ACCURACY_I _{OCP}	$I_{OCP}=1.1\text{A}$		± 10		%
OCP deglitch time	$T_{DEGLITCH_OCP}$			0.3		ms
OTP Function						
OTP threshold temperature	T_{OTP}	$V_{IN}=5\text{V}$		140		$^{\circ}\text{C}$
OTP hysteresis temperature	T_{HYS}	$V_{IN}=5\text{V}$		20		$^{\circ}\text{C}$
Hot-plug ability						
Hot-plug ability		$C_{IN}=0.1\mu\text{F}$, $C_{OUT}=1\mu\text{F}$			30	V

Note 2:Guaranteed by design

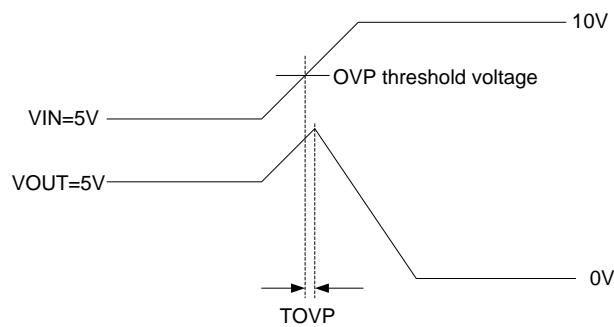

OVP response time test

Function Descriptions**1. Over Current Protection (OCP)**

If the output current exceed the I_{OCP} threshold, the device limits the current for a blanking duration of $T_{DEGLITCH_OCP}$. If the over current situation exceeds the $T_{DEGLITCH_OCP}$, the switch will turned off, and the Fault pin is go low.

2. Over-voltage Lockout (OVLO)

The P14C10 Input has an over voltage protection to protect system. When the VIN voltage rises above V_{OVLO} threshold, the system will turns the switch off.

3. Over Temperature Protection (OTP)

The P14C10 monitors its own internal temperature to prevent thermal failures. The chip turns off the power MOSFET when the internal temperature reaches 140°C , and will resume after the internal temperature is cooled down below 20°C .

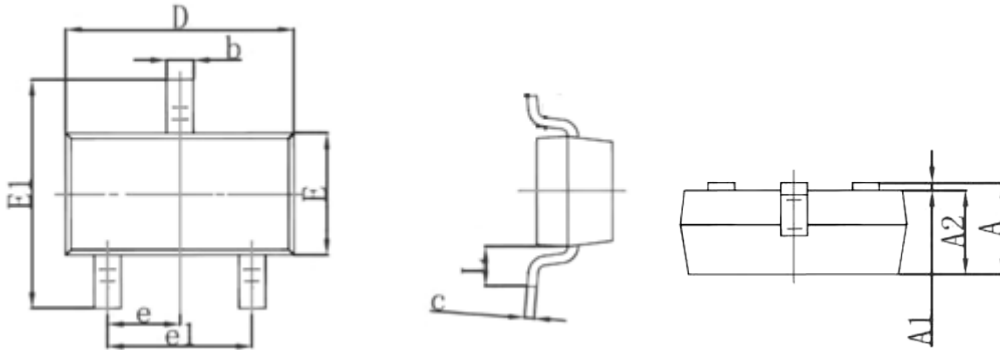
Product dimension (SOT23)

Dim	Millimeters		
	Min.	Typ.	Max.
A	0.90	1.00	1.15
A1	0.00	0.05	0.10
A2	0.89	1.00	1.11
b	0.30	0.40	0.50
c	0.08	0.13	0.18
D	2.80	2.90	3.00
E	1.20	1.30	1.40
E1	2.10	2.30	2.55
e	0.95 Typ.		
e1	1.78	1.90	2.04
L	0.550 Ref.		

IMPORTANT NOTICE

 and **Prisemi**[®] are registered trademarks of **Prisemi Electronics Co., Ltd (Prisemi)** ,Prisemi reserves the right to make changes without further notice to any products herein. Prisemi makes no warranty, representation or guarantee regarding the suitability of its products for any particular purpose, nor does Prisemi assume any liability arising out of the application or use of any product or circuit, and specifically disclaims any and all liability, including without limitation special, consequential or incidental damages. “Typical” parameters which may be provided in Prisemi data sheets and/or specifications can and do vary in different applications and actual performance may vary over time. All operating parameters, including “Typical” must be validated for each customer application by customer’s technical experts. Prisemi does not convey any license under its patent rights nor the rights of others. The products listed in this document are designed to be used with ordinary electronic equipment or devices, Should you intend to use these products with equipment or devices which require an extremely high level of reliability and the malfunction of with would directly endanger human life (such as medical instruments, aerospace machinery, nuclear-reactor controllers, fuel controllers and other safety devices), please be sure to consult with our sales representative in advance.

Prisemi reserves the right to change the circuitry and/or specifications without notice at any time. Customers should obtain the latest relevant information and datasheets before placing orders and should verify that such information is current and complete.

Website: <http://www.prisemi.com>

For additional information, please contact your local Sales Representative.

©Copyright 2009, Prisemi Electronics

 **Prisemi**[®] is a registered trademark of Prisemi Electronics.

All rights are reserved.