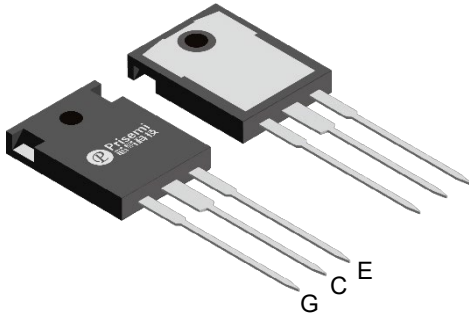
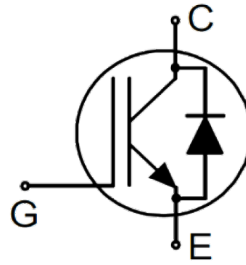
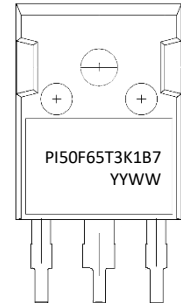

Description

TO-247-3L

Circuit Diagram

Marking (Top View)
Feature

- Easy paralleling capability due to positive temperature coefficient in $V_{CE(sat)}$
- Low EMI
- Low Gate Charge
- Low Saturation Voltage $V_{CE(sat)}$
- Maximum junction temperature $T_{VJmax}=175^{\circ}C$

Applications

- UPS
- EV-Charger
- Solar String Inverter
- Energy Storage Inverter

Absolute maximum rating@25°C

Parameter	Symbol	Value	Units
Collector-Emitter Voltage	V_{CE}	650	V
Gate-Emitter Voltage	V_{GE}	± 20	V
Transient Gate-emitter Voltage ($t_p \leq 10\mu s, D < 0.010$)		± 30	
Collector Current	I_C	$T_c = 25^{\circ}C$	100
		$T_c = 100^{\circ}C$	50
Pulsed Collector Current	I_{CM}	200	A
Diode Current	I_F	$T_c = 25^{\circ}C$	100
		$T_c = 100^{\circ}C$	50
Diode Pulsed Current	I_{FM}	200	A
Power Dissipation	P_D	$T_c = 25^{\circ}C$	250
		$T_c = 100^{\circ}C$	129
Operating Junction Temperature	T_{VJ}	-40~+175	$^{\circ}C$
Storage Temperature	T_{STG}	-55~+150	$^{\circ}C$

Electrical characteristics per line@25°C (unless otherwise specified)

Parameter	Symbol	Conditions	Min.	Typ.	Max.	Units	
Collector-Emitter Breakdown Voltage	BV_{CE}	-	650	-	-	V	
C-E Leakage Current	I_{CES}	$V_{CE}=650V, V_{GE}=0V$	-	-	50	μA	
G-E Leakage Current	I_{GES}	$V_{GE}=\pm 20V, V_{CE}=0V$	-	-	100	nA	
Transconductance	g_{fs}	$V_{GE}=20V, I_C=50A$	-	58	-	S	
Gate-Emitter Threshold Voltage	$V_{GE(th)}$	$I_C=0.25mA, V_{CE}=V_{GE}$	3.6	4.2	4.8	V	
Collector-Emitter Saturation Voltage	$V_{CE(sat)}$	$I_C=50A, V_{GE}=15V$	$T_{VJ}=25^\circ C$	-	1.61	2.0	V
			$T_{VJ}=125^\circ C$	-	1.92	-	
			$T_{VJ}=175^\circ C$	-	2.0	-	
Diode forward voltage	V_F	$I_C=50A, V_{GE}=0V$	$T_{VJ}=25^\circ C$	-	1.9	-	V
			$T_{VJ}=125^\circ C$	-	1.6	-	
			$T_{VJ}=175^\circ C$	-	1.45	-	
Input Capacitance	C_{ies}	$V_{CE}=25V, V_{GE}=0V, f=1MHz$	-	1900	-	pF	
Output Capacitance	C_{oes}		-	140	-		
Reverse Transfer Capacitance	C_{res}		-	15	-		
Total Gate Charge	Q_g	$V_{CE}=520V, V_{GE}=0V \text{ to } 15V, I_C=50A$	-	72	-	nC	
Gate to Emitter Charge	Q_{ge}		-	11	-		
Gate to Collector Charge	Q_{gc}		-	19	-		
Turn-on Delay Time	$t_{d(on)}$	$V_{CC}=400V, I_C=50A, V_{GE}=15V, R_G=12\Omega, \text{ Inductive Load}$	-	18	-	ns	
Rise Time	t_r		-	32	-		
Turn-off Delay Time	$t_{d(off)}$		-	109	-		
Fall Time	t_f		-	33	-		
Turn-on Energy Loss	E_{on}	$V_{CC}=400V, I_C=50A, V_{GE}=15V, R_G=12\Omega, \text{ Inductive Load}$	-	1.0	-	mJ	
Turn-off Energy Loss	E_{off}		-	0.79	-		
Total Switching Loss	E_{st}		-	1.79	-		
Diode Reverse Recovery Time	T_{rr}	$V_R=400V, I_F=50A, di/dt=400A/\mu S$	-	56	-	ns	
Diode Reverse Recovery Charge	Q_{rr}		-	0.27	-	μC	
Diode Reverse Recovery Current	I_{rm}		-	8.0	-	A	

Thermal Resistance

Parameter	Symbol	Min.	Typ.	Max.	Unit
Thermal Resistance, IGBT Junction-Ambient	$R_{th(J-A)}$	-	-	40	$^{\circ}C/W$
Thermal Resistance, IGBT Junction to Case	$R_{th(J-C)}$	-	-	0.58	$^{\circ}C/W$
Thermal Resistance, FRD Junction to Case	$R_{th(J-C)}$	-	-	0.65	$^{\circ}C/W$

Typical Characteristics

Fig 1. Typical Output Characteristics (25°C)

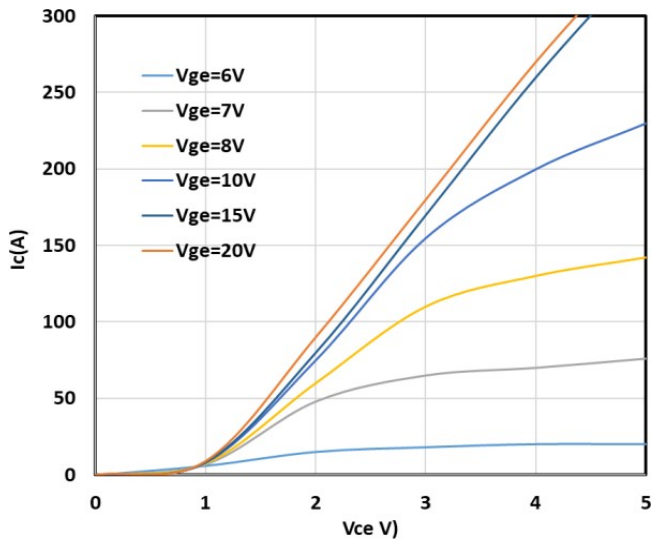

Fig 2. Typical Output characteristics (175°C)

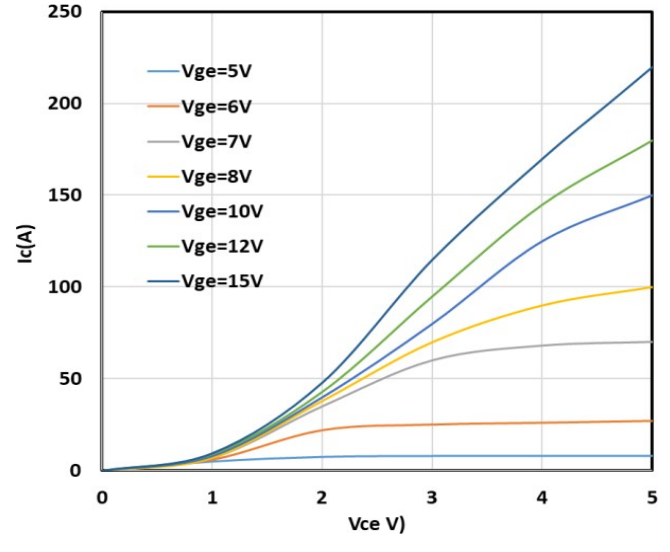

Fig 3. Forward Bias Safe Operating Area

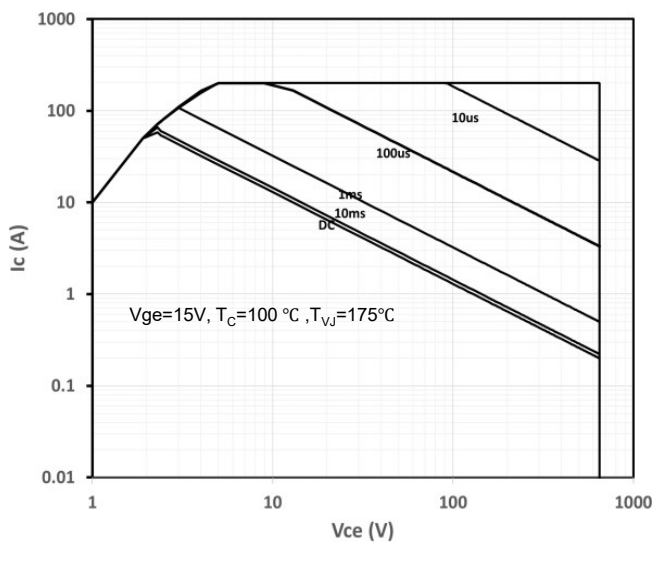
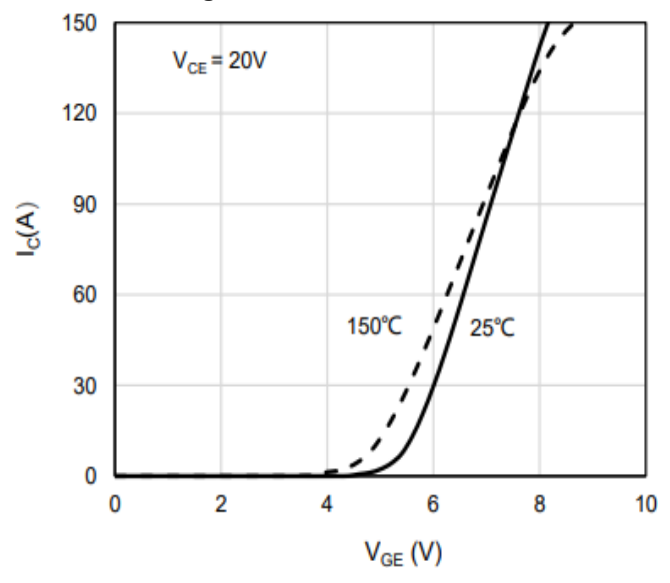

Fig 4. Transfer Characteristics



Typical Characteristics

Fig 5. Gate Charge

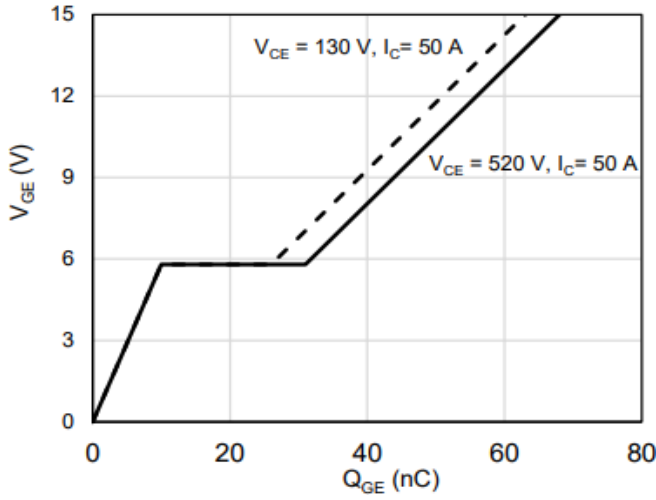

Fig 6. Typical Capacitance

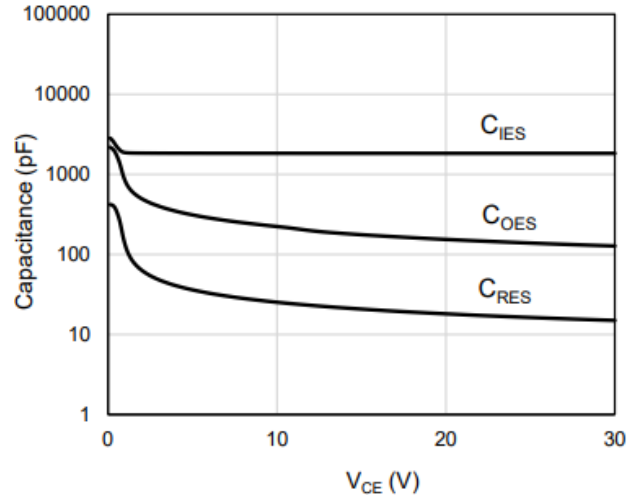

Fig 7. Vcesat vs. Junction Temperature

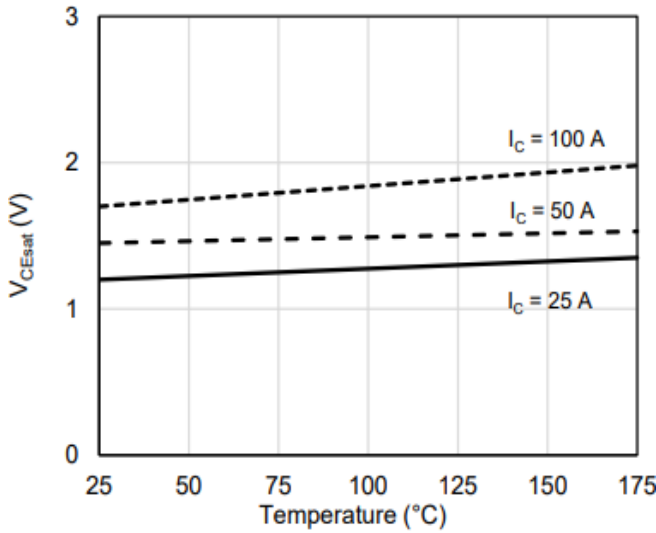

Fig 8. Typical Diode VF vs. IF Characteristic

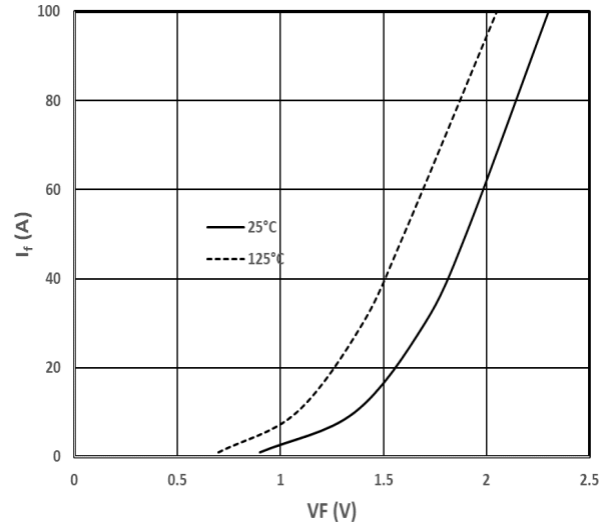

Fig 9. Switching Energy vs. Collector Current (25°C)

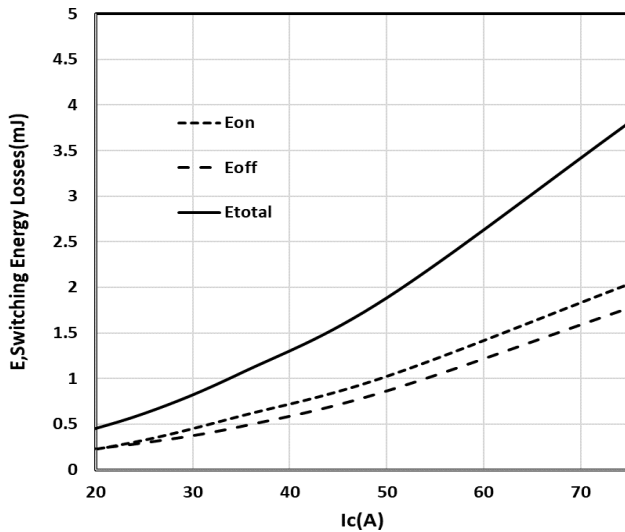
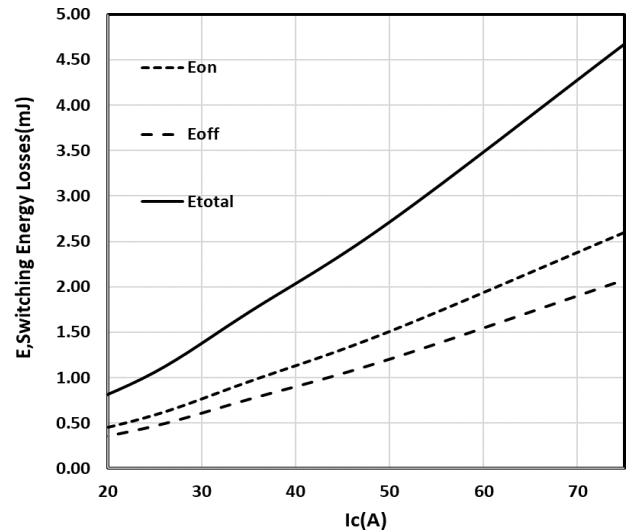

Fig 10. Switching Energy vs. Collector Current (150°C)



Typical Characteristics

Fig 11. Switching Energy vs. Gate Resistance

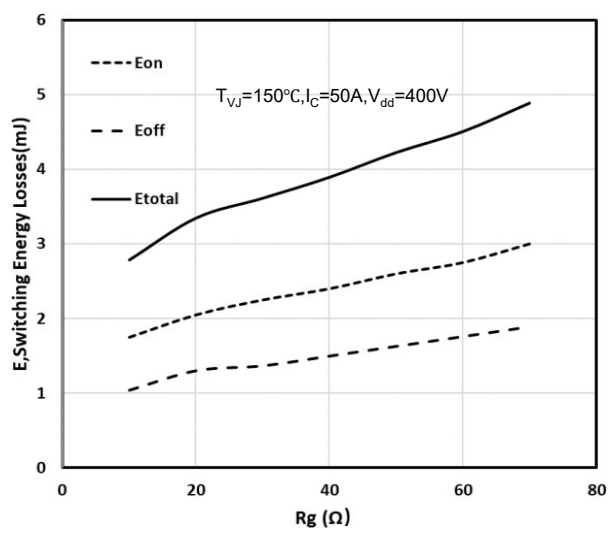

Fig 12. Switching Energy vs. Junction Temperature

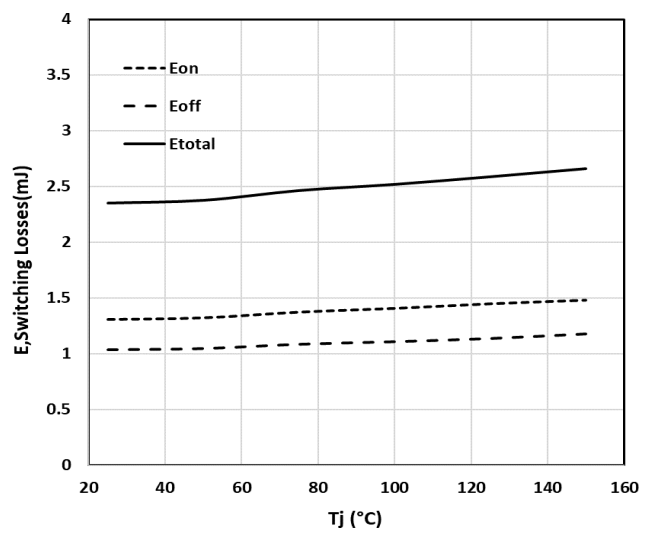

Fig 13. Threshold Voltage vs. Junction Temperature

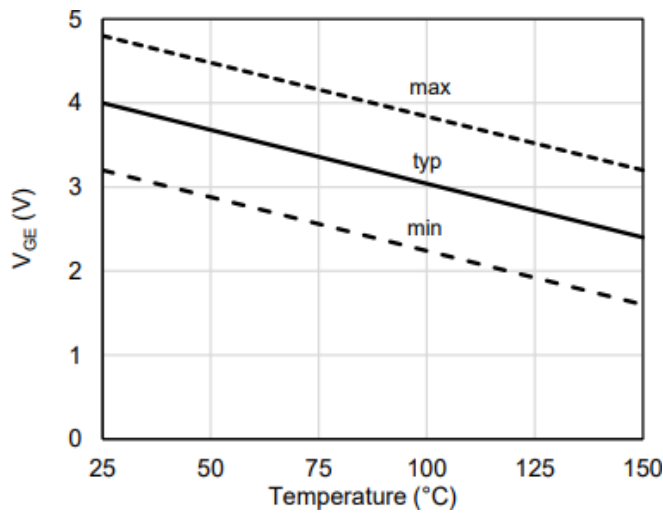

Fig 14. Transient Thermal Impedance IGBT

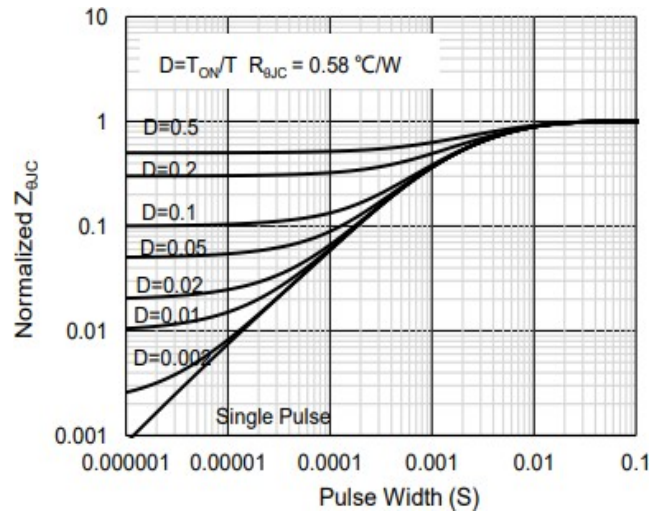

Fig 15. Transient Thermal Impedance Diode

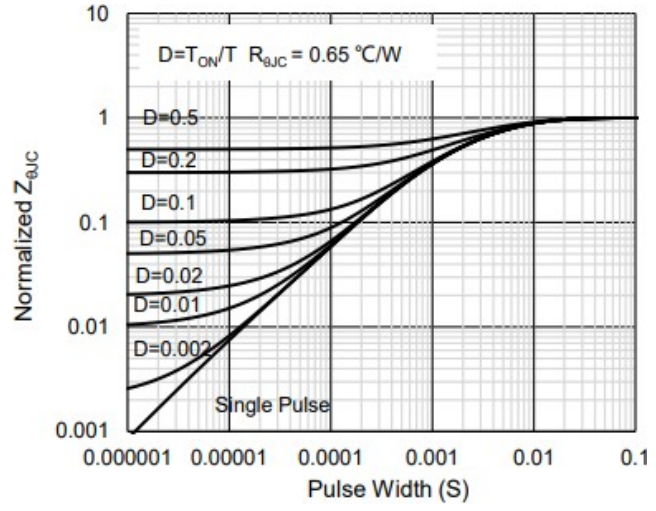

Fig 16. Switching Test Circuit & Waveforms

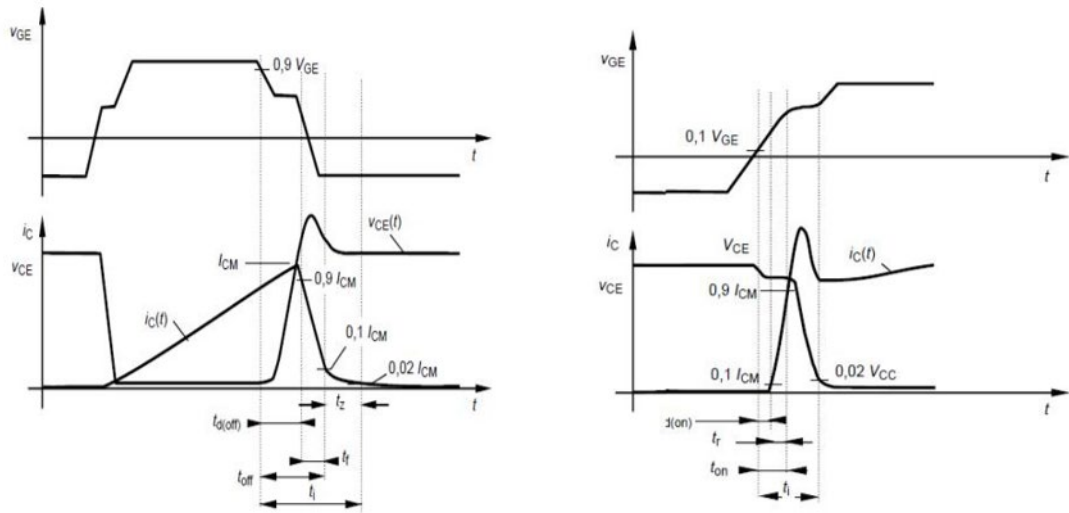
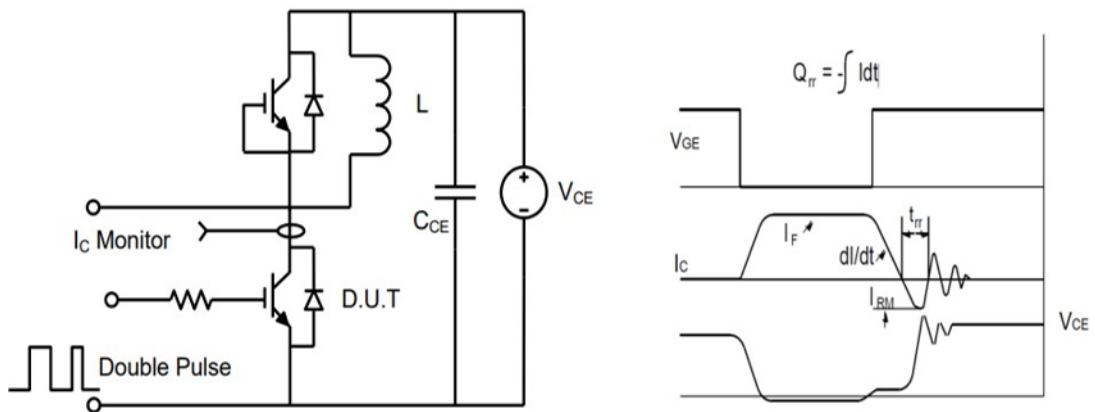
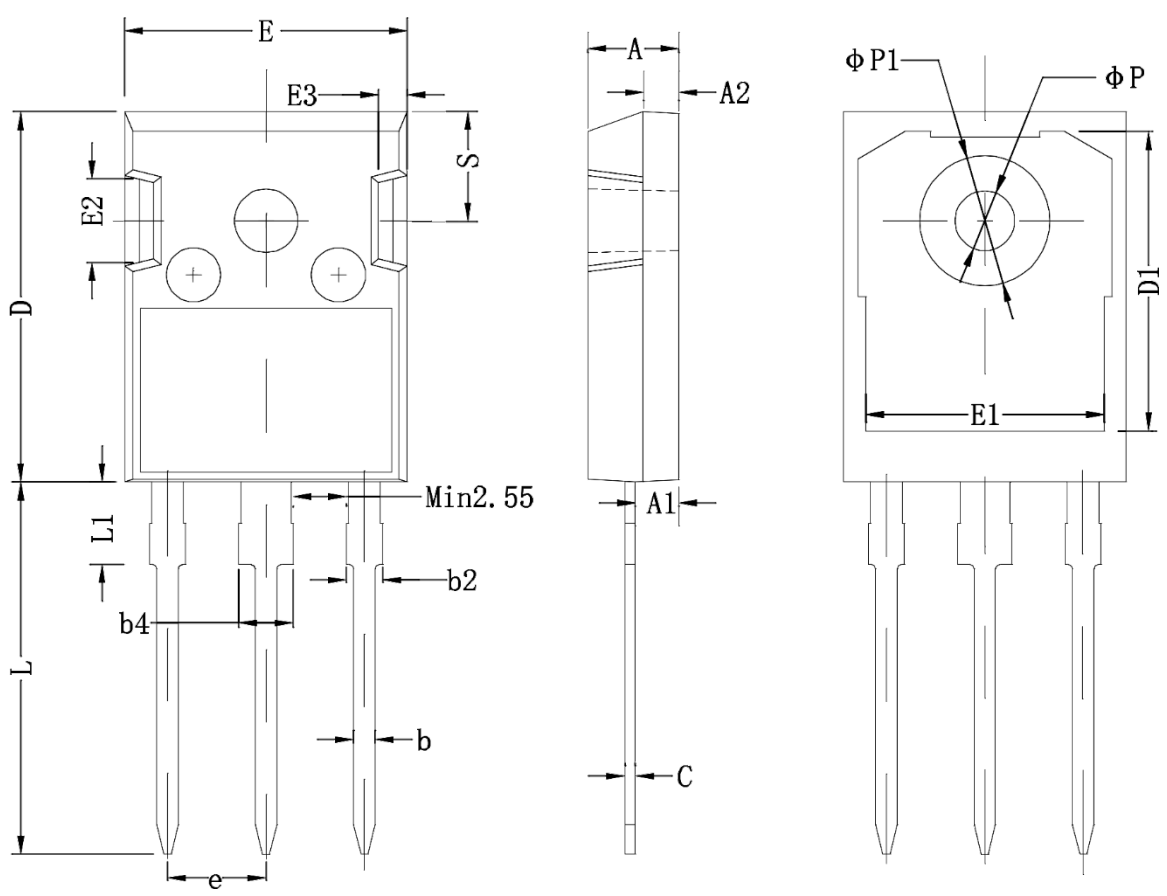

Fig 17. Diode Recovery Test Circuit & Waveforms



Product Dimension (TO-247-3L)



Dim	Millimeters			Dim	Millimeters		
	Min	Nom	Max		Min	Nom	Max
A	4.80	5.00	5.20	E1	13.00	13.30	13.60
A1	2.21	2.41	2.59	E2	4.80	5.00	5.20
A2	1.85	2.00	2.15	E3	2.30	2.50	2.70
b	1.11	1.21	1.36	e	5.44 BSC.		
b2	1.91	2.01	2.21	L	19.62	19.92	20.22
b4	2.91	3.01	3.21	L1	-	-	4.30
c	0.51	0.61	0.75	φP	3.40	3.60	3.80
D	20.70	21.00	21.30	φP1	-	-	7.30
D1	16.25	16.55	16.85	S	6.15 BSC.		
E	15.50	15.80	16.10				

IMPORTANT NOTICE

 and **Prisemi**[®] are registered trademarks of **Prisemi Electronics Co., Ltd (Prisemi)**, Prisemi reserves the right to make changes without further notice to any products herein. Prisemi makes no warranty, representation or guarantee regarding the suitability of its products for any particular purpose, nor does Prisemi assume any liability arising out of the application or use of any product or circuit, and specifically disclaims any and all liability, including without limitation special, consequential or incidental damages. “Typical” parameters which may be provided in Prisemi data sheets and/or specifications can and do vary in different applications and actual performance may vary over time. All operating parameters, including “Typicals” must be validated for each customer application by customer’s technical experts. Prisemi does not convey any license under its patent rights nor the rights of others. The products listed in this document are designed to be used with ordinary electronic equipment or devices, Should you intend to use these products with equipment or devices which require an extremely high level of reliability and the malfunction of with would directly endanger human life (such as medical instruments, aerospace machinery, nuclear-reactor controllers, fuel controllers and other safety devices), please be sure to consult with our sales representative in advance.

Website: <http://www.prisemi.com>

For additional information, please contact your local Sales Representative.

©Copyright 2009, Prisemi Electronics

 **Prisemi**[®] is a registered trademark of Prisemi Electronics.

All rights are reserved.