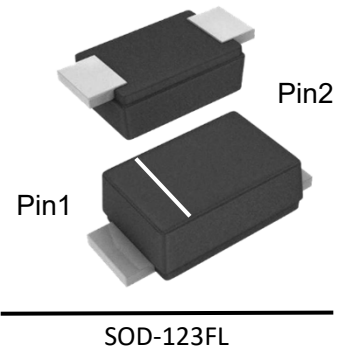
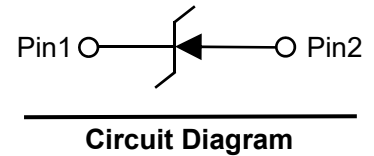

Feature

- The plastic package carries Underwriters Laboratory Flammability Classification 94V-0.
- For surface mounted applications.
- Built-in strain relief, ideal for automated placement.
- Low reverse leakage.
- High forward surge current capability.
- High temperature soldering guaranteed 260 °C/10 seconds at terminals.

Mechanical Characteristics

- Case : Molded plastic body
- Terminals : Solder plated, solderable per MIL-STD-750, Method 2026
- Polarity : Polarity symbol marking on body
- Mounting Position : Any
- Weight : 0.0007 ounce, 0.02 grams

Absolute maximum rating@25°C

Parameter	Symbol	PSBD1D F20V3H X	PSBD1D F40V3H X	PSBD1D F60V3H X	PSBD1D F80V3H X	PSBD1D F100V3 HX	PSBD1D F150V3 HX	PSBD1D F200V3 HX	Units
Maximum Repetitive Peak Reverse Voltage	V_{RRM}	20	40	60	80	100	150	200	V
Maximum RMS Voltage	V_{RMS}	14	28	42	56	70	105	140	V
Maximum DC Blocking Voltage	V_{DC}	20	40	60	80	100	150	200	V
Forward Current @ $T_L = 100^\circ\text{C}$	$I_{F(AV)}$	3.0							A
Peak Forward Surge Current 8.3 ms Single Half Sine-wave Superimposed on Rated Load	I_{FSM}	70							A
Max Instantaneous Forward Voltage at 3 A	V_F	0.55	0.7	0.85	0.95				V
Reverse Current	$T_a = 25^\circ\text{C}$	0.2			0.05			mA	
	$T_a = 100^\circ\text{C}$	20			5.0				
Typical Thermal Resistance	$R_{\theta JA}$	85							$^\circ\text{C/W}$
Operating Junction Temperature Range	T_J	-55 ~ +125			-55 ~ +150			$^\circ\text{C}$	
Storage Temperature Range	T_{STG}	-55 ~ +150							$^\circ\text{C}$

Typical Characteristics

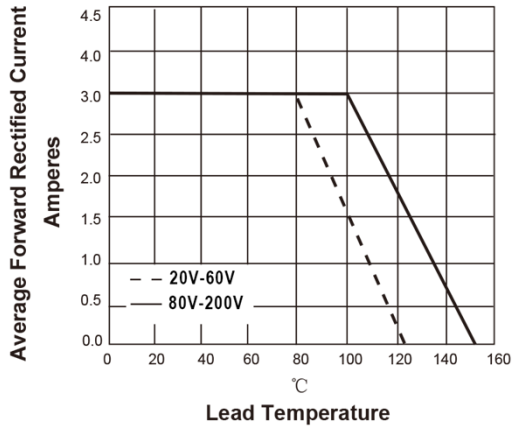

FIG. 1- DERATING CURVE OUTPUT RECTIFIED CURRENT

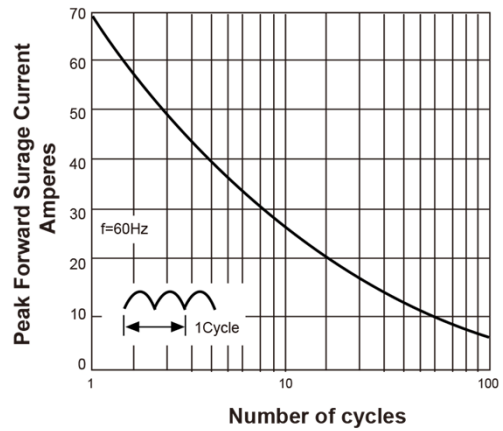

FIG. 2-MAXIMUM NON-REPETITIVE PEAK FORWARD SURGE CURRENT PER LEG

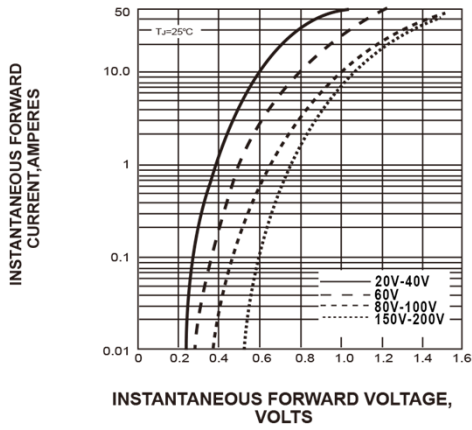

FIG. 3-TYPICAL FORWARD VOLTAGE CHARACTERISTICS

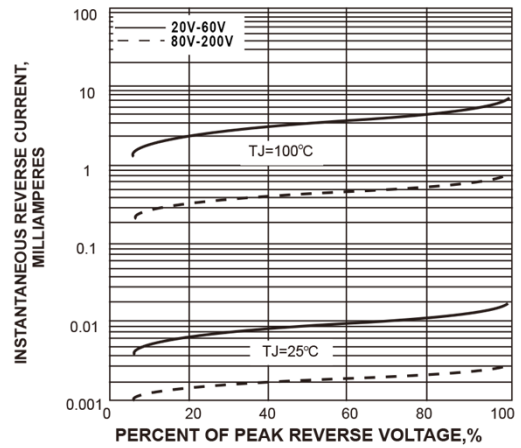
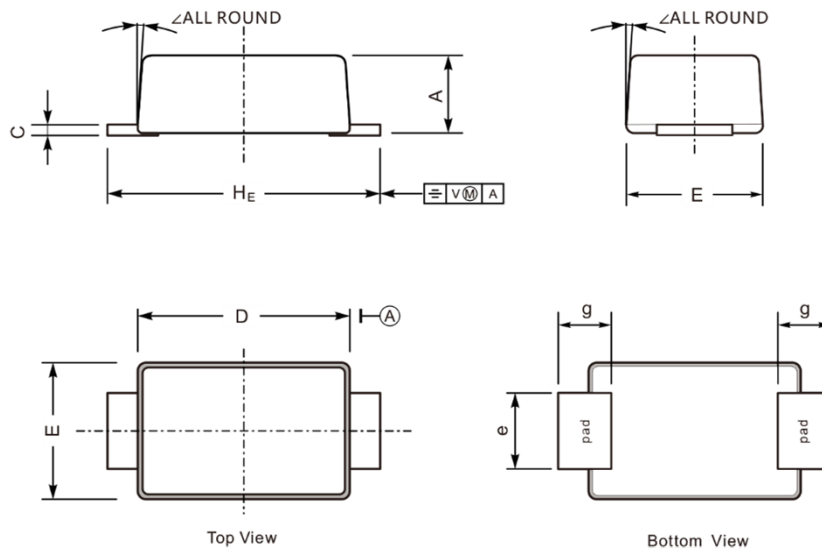
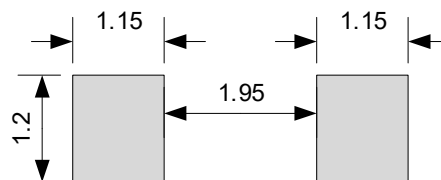

FIG. 4-TYPICAL REVERSE LEAKAGE CHARACTERISTICS

Product Dimension (SOD-123FL)



Dim	Millimeters		Inches	
	Min	Max	Min	Max
A	0.90	1.30	0.035	0.051
C	0.10	0.30	0.004	0.012
D	2.60	3.00	0.102	0.118
E	1.60	2.00	0.063	0.079
e	0.80	1.10	0.031	0.043
g	0.70	0.90	0.028	0.035
HE	3.60	4.00	0.142	0.157
∠	7°			



Unit: mm

Suggested PCB Layout

Ordering information

Package	Reel	Shipping
SOD-123FL	7"	3000 / Tape & Reel

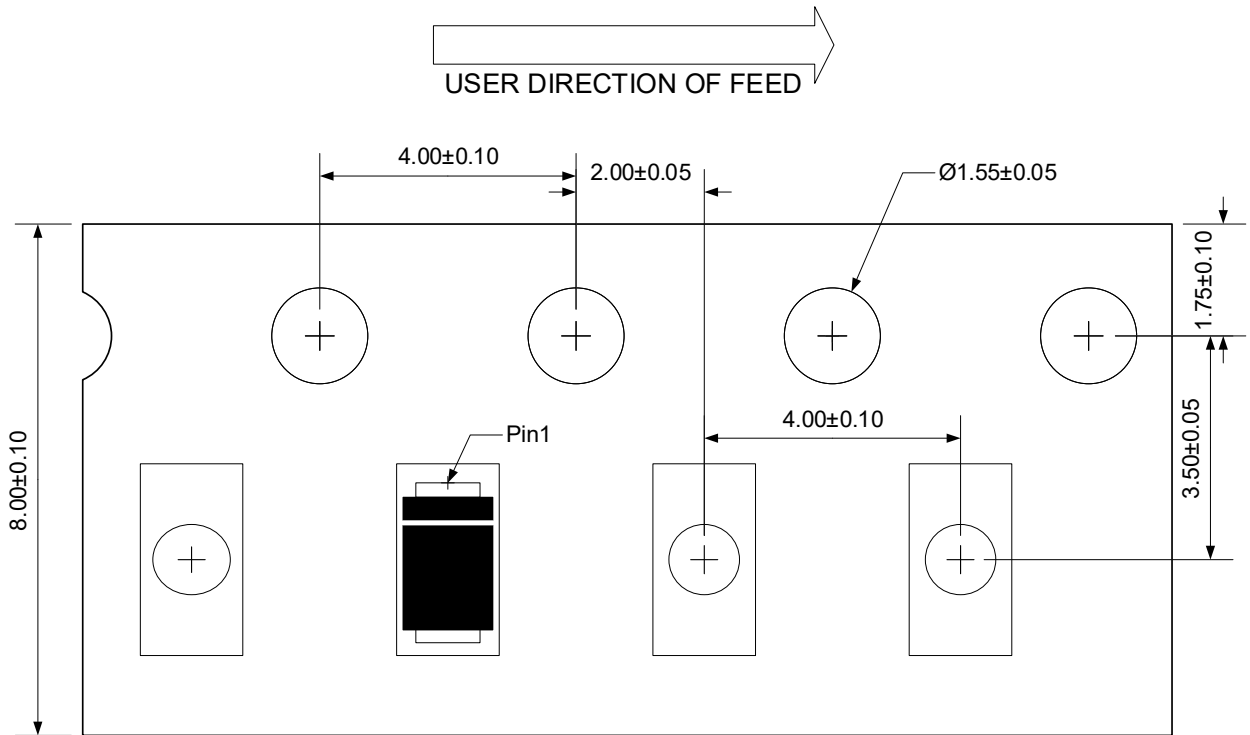

Unit:mm

IMPORTANT NOTICE

 and **Prisemi**[®] are registered trademarks of **Prisemi Electronics Co., Ltd** (Prisemi), Prisemi reserves the right to make changes without further notice to any products herein. Prisemi makes no warranty, representation or guarantee regarding the suitability of its products for any particular purpose, nor does Prisemi assume any liability arising out of the application or use of any product or circuit, and specifically disclaims any and all liability, including without limitation special, consequential or incidental damages. "Typical" parameters which may be provided in Prisemi data sheets and/or specifications can and do vary in different applications and actual performance may vary over time. All operating parameters, including "Typicals" must be validated for each customer application by customer's technical experts. Prisemi does not convey any license under its patent rights nor the rights of others. The products listed in this document are designed to be used with ordinary electronic equipment or devices, Should you intend to use these products with equipment or devices which require an extremely high level of reliability and the malfunction of with would directly endanger human life (such as medical instruments, aerospace machinery, nuclear-reactor controllers, fuel controllers and other safety devices), please be sure to consult with our sales representative in advance.

Website: <http://www.prisemi.com>

For additional information, please contact your local Sales Representative.

©Copyright 2009, Prisemi Electronics

 **Prisemi**[®] is a registered trademark of Prisemi Electronics.

All rights are reserved.