

Description

Product Summary		
$V_{DS}(V)$	$R_{DS(on)}(m\Omega)(Typ)$	$I_D(A)$
700	180	13

Feature

- Easy to use, compatible with standard gate drivers
- Excellent $Q_G \times R_{DS(on)}$ figure of merit (FOM)
- Low Q_{RR} , no free-wheeling diode required
- Low switching loss
- RoHS compliant and Halogen-free

Applications

- High efficiency power supplies
- Telecom and datacom
- Automotive
- Servo motors

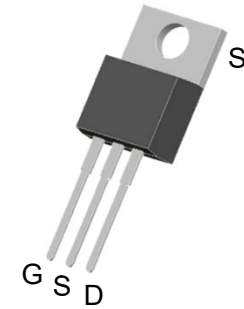
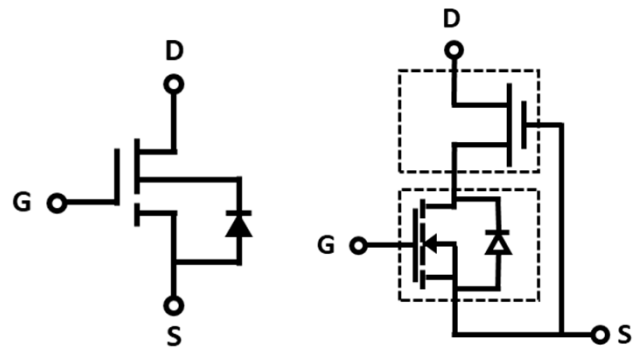
TO-220 (Top View)

Schematic Symbol
Cascode Device Structure
Absolute maximum rating@25°C

Parameter	Symbol	Rating	Unit
Drain-Source Voltage	V_{DS}	700	V
Gate-Source Voltage	V_{GS}	± 20	V
Transient Drain-Source Voltage ¹⁾	V_{TDS}	800	V
Continuous Drain Current	I_D	$T_C=25^\circ C$	13
		$T_C=100^\circ C$	8
Pulsed Drain Current (Pulse Width: 100 μs)	I_{DM}	$T_C=25^\circ C$	41
		$T_C=150^\circ C$	30
Power Dissipation	P_D	57	W
Soldering Peak Temperature	T_{CSOLD}	260	$^\circ C$
Operating Junction and Storage Temperature	T_J, T_{STG}	-55 to 150	$^\circ C$

Thermal Resistance

Parameter	Symbol	Min	Typ	Max	Unit
Thermal Resistance, Junction-to-Case	$R_{\theta JC}$	-	2.2	-	$^\circ C/W$
Thermal Resistance, Junction-to-Ambient ²⁾	$R_{\theta JA}$	-	50	-	$^\circ C/W$

Electrical characteristics per line@25°C (unless otherwise specified)

Parameter	Symbol	Conditions	Min.	Typ.	Max.	Units	
Statistic Characteristics							
Maximum Drain-Source Voltage	V_{DS-Max}	$V_{GS} = 0V$	700	-	-	V	
Drain-Source Breakdown Voltage	BV_{DSS}	$V_{GS} = 0V, I_D = 250\mu A$	-	1000	-	V	
Zero Gate Voltage Drain Current	I_{DSS}	$V_{DS}=700V,$ $V_{GS}=0V$	$T_J=25^\circ C$	-	5	20	μA
			$T_J=150^\circ C$	-	50	-	
Gate-Body Leakage Current	I_{GSS}	$V_{GS} = \pm 20V, V_{DS} = 0V$	-	-	± 150	nA	
Gate Threshold Voltage	$V_{GS(th)}$	$V_{DS} = V_{GS}, I_D = 500\mu A$	3	4	5	V	
Gate threshold voltage temperature coefficient	$\Delta V_{GS(th)}/T_J$		-	-10.7	-	mV/°C	
Drain-Source On-State Resistance ³⁾	$R_{DS(ON)}$	$V_{GS}=12V,$ $I_D=4A$	$T_J=25^\circ C$	-	180	225	mΩ
			$T_J=150^\circ C$	-	360	-	
Dynamic Characteristics							
Input Capacitance	C_{iss}	$V_{DS} = 400V, V_{GS} = 0V,$ $f = 1MHz$	-	515	-	pF	
Output Capacitance	C_{oss}		-	23	-		
Reverse Transfer Capacitance	C_{rss}		-	1.2	-		
Effective Output Capacitance, Energy Related	$C_{o(er)}$	$V_{GS} = 0V,$ $V_{DS} = 0-400V$	-	35	-	pF	
Effective Output Capacitance, Time Related	$C_{o(tr)}$		-	86	-		
Output Charge	Q_{oss}		-	34.5	-		nC
Turn-on Delay Time	$t_{d(on)}$	$V_{DS} = 400V, I_D = 3A,$ $V_{GS} = 0-12V, R_G = 47\Omega$	-	43	-	ns	
Turn-on Rise Time	t_r		-	15	-		
Turn-Off Delay Time	$t_{d(off)}$		-	39	-		
Turn-Off Fall Time	t_f		-	11	-		
Total Gate Charge	Q_g	$V_{DS} = 400V, I_D = 6A,$ $V_{GS} = 0-12V$	-	15	-	nC	
Gate-Source Charge	Q_{gs}		-	4.9	-		
Gate-Drain Charge	Q_{gd}		-	5.5	-		
Reverse Diode Characteristics							
Diode Forward Voltage	V_{SD}	$V_{GS}=0V, I_S=4A$	-	1.3	-	V	
			$V_{GS}=0V,$ $I_S=8A$	$T_J=25^\circ C$	-		1.8
		$T_J=150^\circ C$		-	3		-
Reverse Recovery Time	t_{rr}	$V_{GS}=0V, I_S=8A,$ $V_{DD}=400V,$ $di/dt=1000A/\mu s$	-	18	-	ns	
Reverse Recovery Charge	Q_{rr}		-	34.5	-	μC	

Notes:

- Off-state spike duty cycle < 0.01, spike duration < 2μs
- Device on one layer epoxy PCB for drain connection (vertical and without air stream cooling, with 6cm²copper area and 70μm thickness)
- Dynamic on-resistance; see Figure 19 and 20 for test circuit and configurations

Typical Characteristics

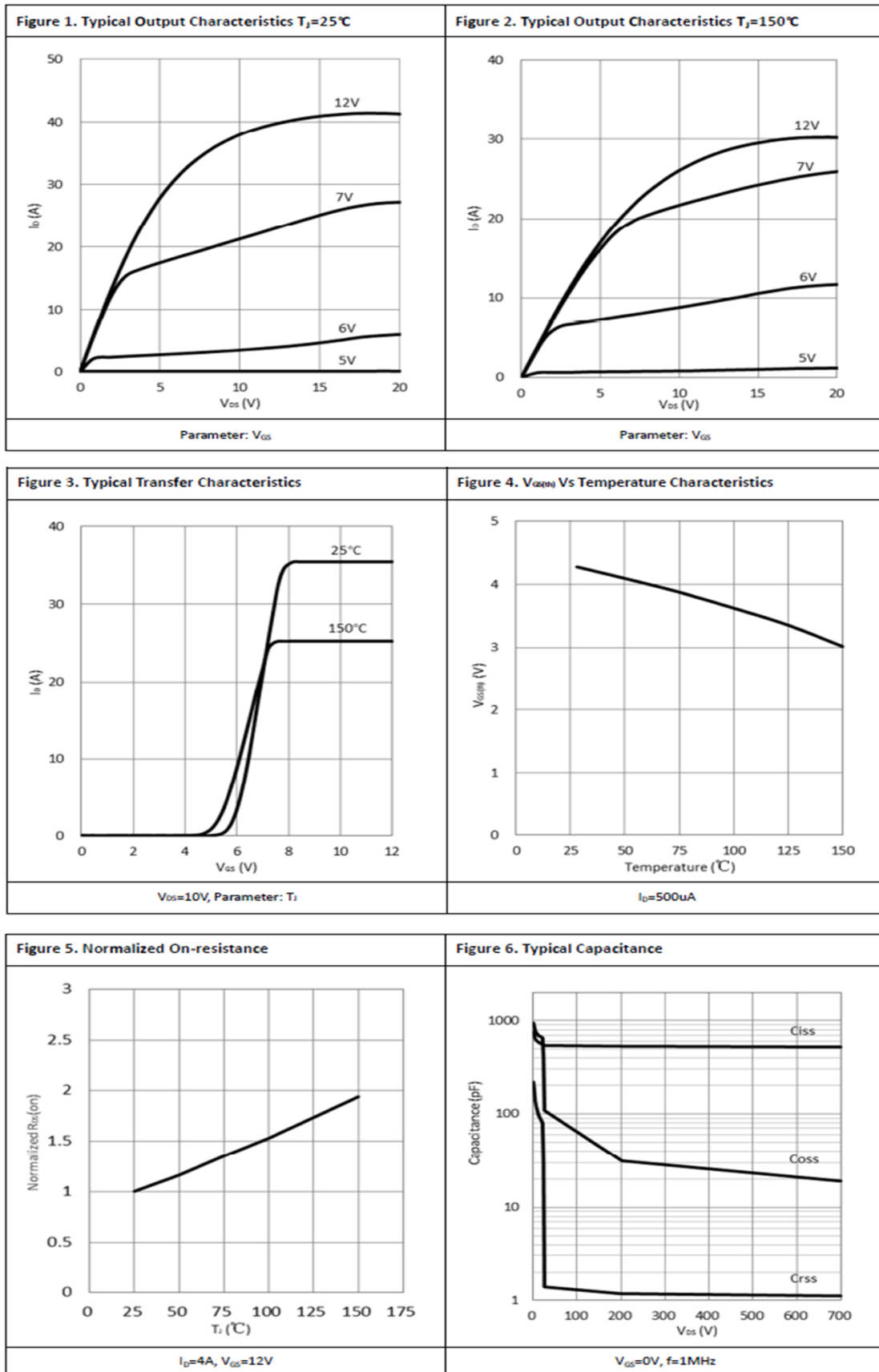

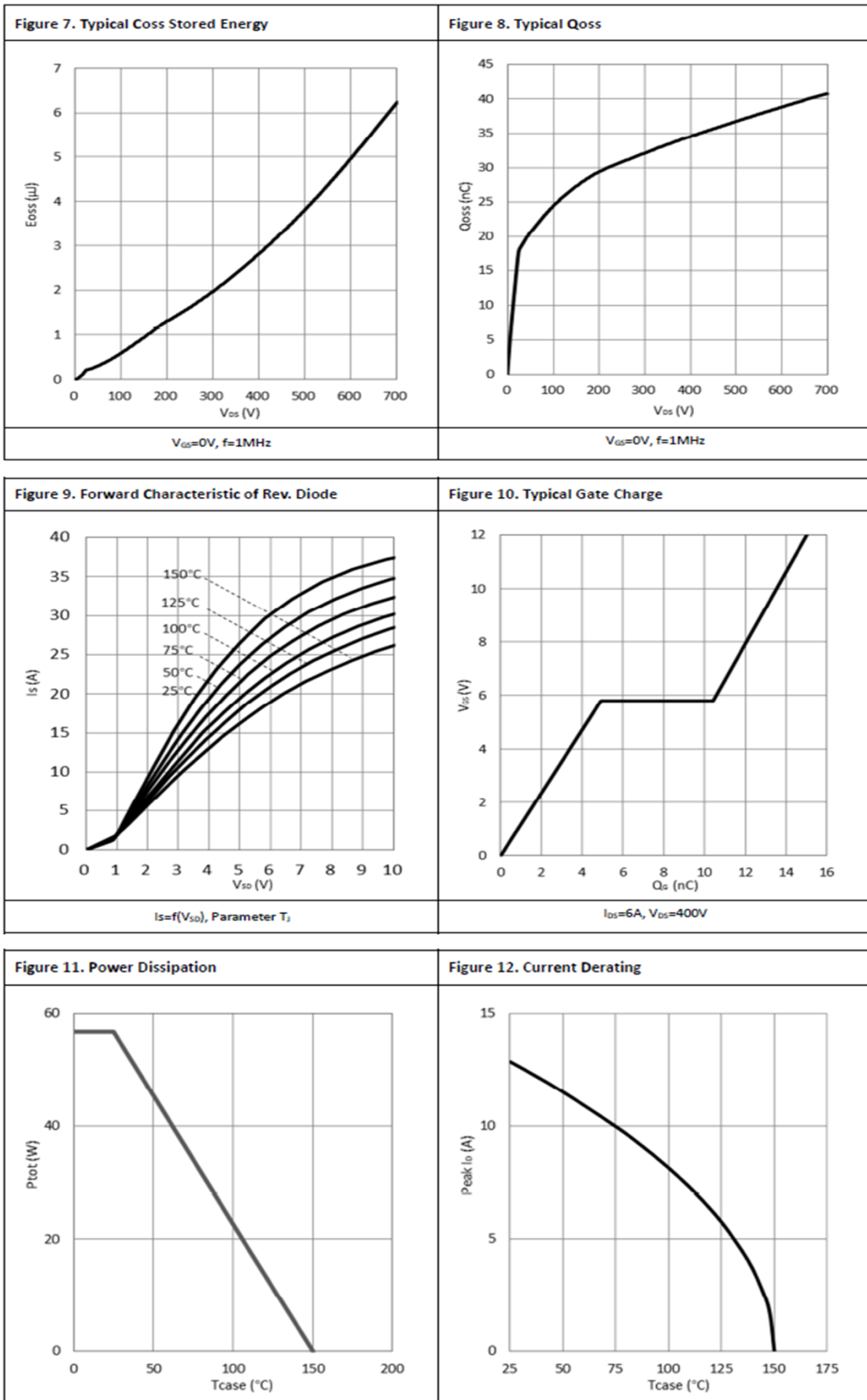

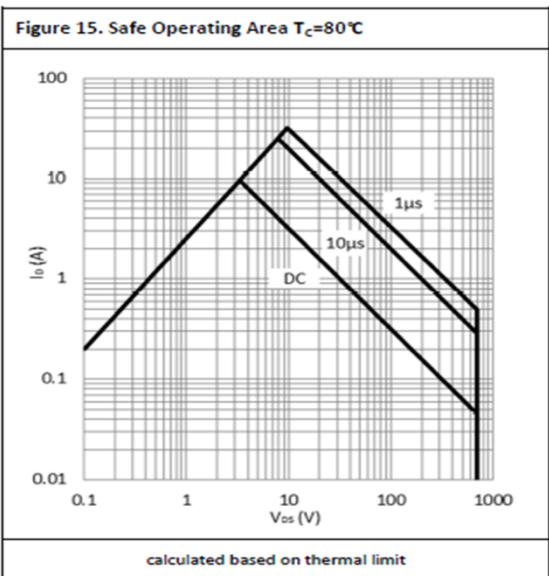
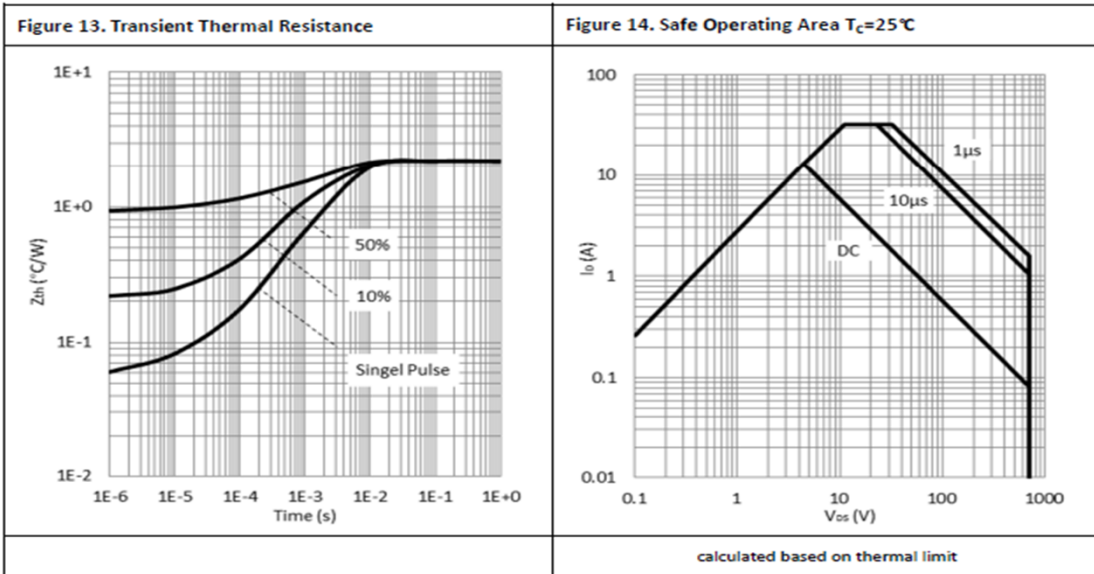

Test Circuits and Waveforms

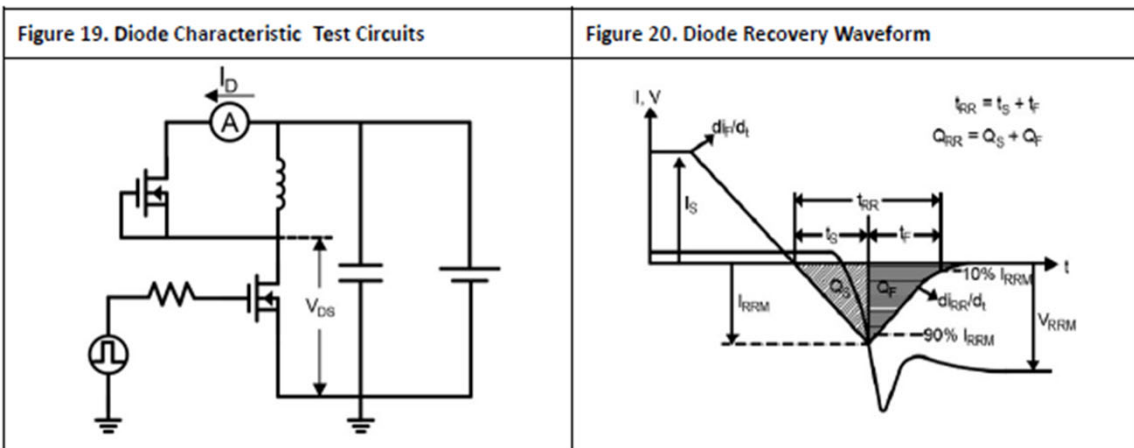
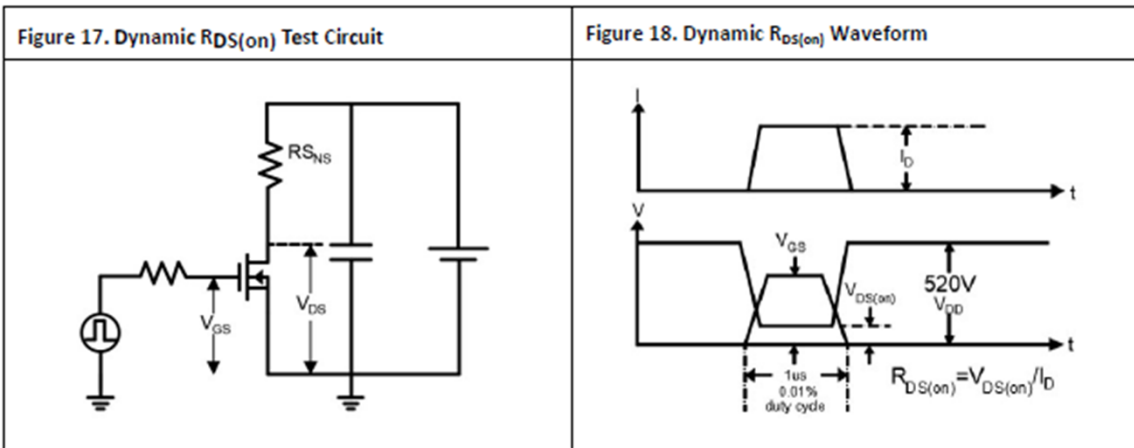
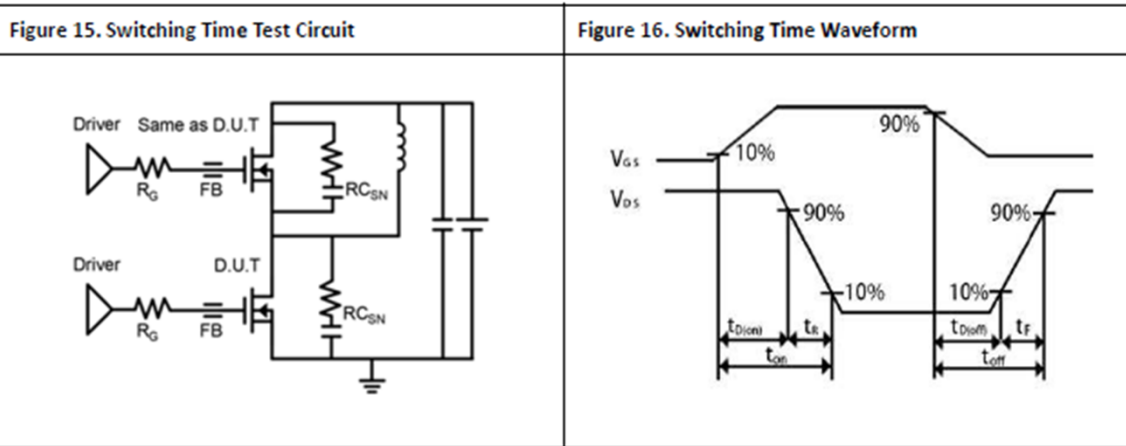

Product Dimension (TO-220)

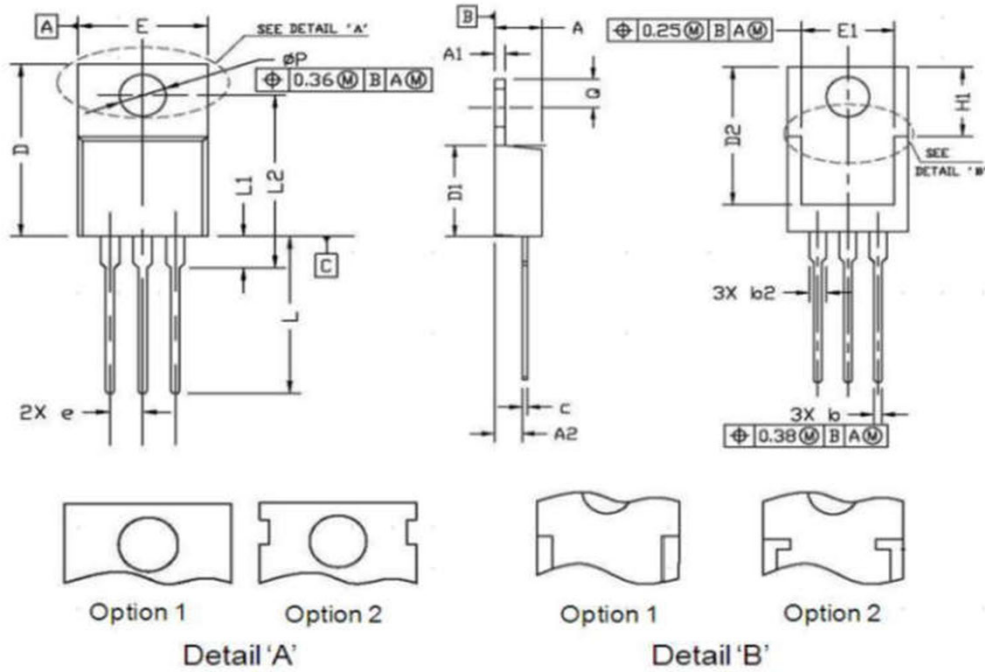

SYMBOL	Millimeter	
	Min	Max
A	4.30	4.80
A1	1.20	1.45
A2	2.20	2.90
b	0.69	0.95
b2	1.00	1.60
c	0.33	0.65
D	14.70	16.20
D1	8.59	9.65
D2	11.75	13.60
e	2.54BSC	
E	9.60	10.60
E1	7.00	8.46
H1	6.20	7.00
L	12.60	14.80
L1	2.70	3.80
L2	12.13	16.50
Q	2.40	3.10
P	3.50	3.90

IMPORTANT NOTICE

 and **Prisemi**[®] are registered trademarks of **Prisemi Electronics Co., Ltd** (Prisemi), Prisemi reserves the right to make changes without further notice to any products herein. Prisemi makes no warranty, representation or guarantee regarding the suitability of its products for any particular purpose, nor does Prisemi assume any liability arising out of the application or use of any product or circuit, and specifically disclaims any and all liability, including without limitation special, consequential or incidental damages. "Typical" parameters which may be provided in Prisemi data sheets and/or specifications can and do vary in different applications and actual performance may vary over time. All operating parameters, including "Typicals" must be validated for each customer application by customer's technical experts. Prisemi does not convey any license under its patent rights nor the rights of others. The products listed in this document are designed to be used with ordinary electronic equipment or devices, Should you intend to use these products with equipment or devices which require an extremely high level of reliability and the malfunction of with would directly endanger human life (such as medical instruments, aerospace machinery, nuclear-reactor controllers, fuel controllers and other safety devices), please be sure to consult with our sales representative in advance.

Website: <http://www.prisemi.com>

For additional information, please contact your local Sales Representative.

©Copyright 2009, Prisemi Electronics

 **Prisemi**[®] is a registered trademark of Prisemi Electronics.

All rights are reserved.