

Description

Prisemi GDT's are designed for a high degree of surge protection at a low cost. It operates on the gas physical principle of the highly effective arc discharge. The PG3E6LAxxV10K is used for protecting equipment for which higher voltage limits and holdover voltages are necessary. Com-gaps function as switches which dissipate a mini-mum amount of energy and therefore handle currents that far surpass other types of transient voltage protection.

Features

- Small size
- Very fast response time
- Suitable for direct strikes
- Stable performance over life
- Very low capacitance
- High insulation resistance

Application

- Communication lines
- CATV equipment
- Test equipment
- Data lines, power supply
- Base station
- Medical electronics

Specifications (@25°C)

Type	DC Spark Over Voltage (V)	Impulse Spark Over Voltage (V)	Impulse Discharge Current (A)	Impulse Discharge Current (kA)	AC Discharge Current	Holdover Voltage (V)	Capacitance (pF)	Insulation Resistance (Ω)
	100V/s	1KV/μs	10/1000μs 300Hits	8/20μs 10Hits	50Hz 1s 5Hits		@ 1MHz	
PG3E6LA75V10K	75±25%	≤600	50	10	10	/	<1.5	>10 ⁹
PG3E6LA90V10K	90±25%	≤600	50	10	10	/	<1.5	>10 ⁹
PG3E6LA150V10K	150±25%	≤700	100	10	10	80	<1	>10 ⁹
PG3E6LA230V10K	350±25%	≤800	100	10	10	135	<1	>10 ⁹
PG3E6LA350V10K	350±20%	≤800	100	10	10	135	<1	>10 ⁹
PG3E6LA470V10K	450±20%	≤900	100	10	10	135	<1	>10 ⁹
PG3E6LA600V10K	600±20%	≤1200	100	10	10	135	<1	>10 ⁹

Product dimension

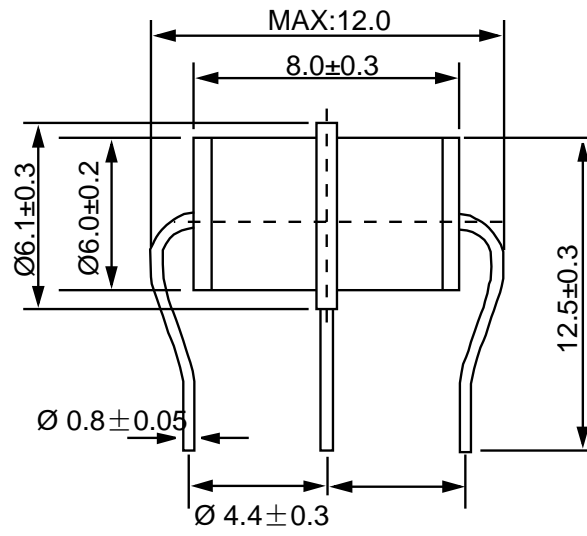

Unit:mm

IMPORTANT NOTICE

 and **Prisemi**[®] are registered trademarks of **Prisemi Electronics Co., Ltd (Prisemi)** ,Prisemi reserves the right to make changes without further notice to any products herein. Prisemi makes no warranty, representation or guarantee regarding the suitability of its products for any particular purpose, nor does Prisemi assume any liability arising out of the application or use of any product or circuit, and specifically disclaims any and all liability, including without limitation special, consequential or incidental damages. "Typical" parameters which may be provided in Prisemi data sheets and/or specifications can and do vary in different applications and actual performance may vary over time. All operating parameters, including "Typicals" must be validated for each customer application by customer's technical experts. Prisemi does not convey any license under its patent rights nor the rights of others. The products listed in this document are designed to be used with ordinary electronic equipment or devices, Should you intend to use these products with equipment or devices which require an extremely high level of reliability and the malfunction of with would directly endanger human life (such as medical instruments, aerospace machinery, nuclear-reactor controllers, fuel controllers and other safety devices), please be sure to consult with our sales representative in advance.

Website: <http://www.prisemi.com>

For additional information, please contact your local Sales Representative.

©Copyright 2009, Prisemi Electronics

 **Prisemi**[®] is a registered trademark of Prisemi Electronics.

All rights are reserved.